

## FRONT ANCHOR INSTALLATIONS

**NOTE:** The diagram below shows driver's side installation. The support brackets are not universal and will not fit either side. Familiarize yourself with the hole numbers for the driver's side installation, then locate the corresponding holes for the passenger side installation.

1. Locate the installation point for the triangular support bracket under truck frame cross member at front of truck bed with the longer side horizontal as shown. (Fig. 2)
2. Fit bracket as shown so that it rests flush against all three surfaces which it contacts (cross frame, outer wall, & vertical support) then mark, center punch, and drill a 1/8" pilot hole at hole location ① then install #8 sheet metal screw. Recheck positioning of support bracket then tighten.
3. Drill 1/8" pilot hole at location ② and install and tighten #8 sheet metal screw.
4. Using centering guide provided, ⓪ drill 1/8" pilot hole (from inside out) at hole location ③
5. Enlarge hole ③ through outer bed wall to 1/2" drilling from the outside.
6. Install chrome step washer onto chrome anchor bolt with stepped side toward head, then insert in hole ③ from the outside. Set anchor bolt with flat sides at top and bottom ⓪, and secure with 1/2" lock washer & nut. (Fig. 1)
7. Drill 3/8" holes at positions ④, ⑤, & ⑥ and install 3/8" hardware. Insert bolt with flat washer downward through access holes in cross frame member at holes ④ & ⑤. Insert bolt with flat washer through hole ⑥. Secure all bolts with 3/8" split lock washer & nut.

Fig. 1

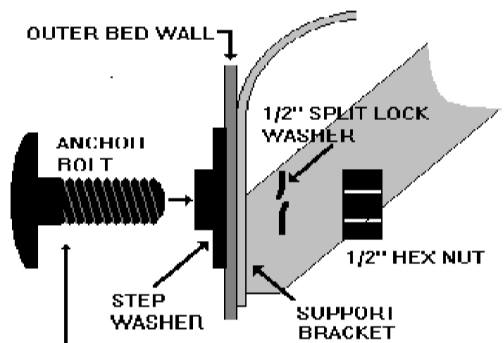
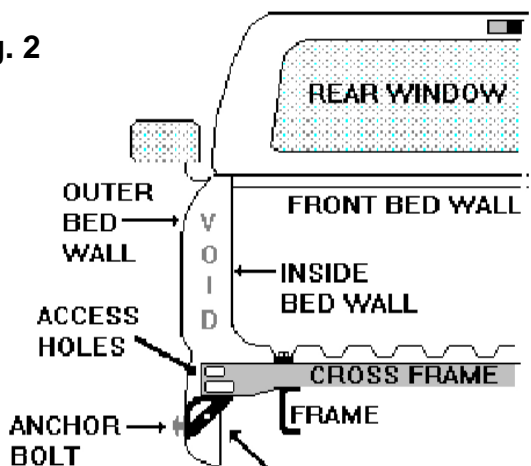
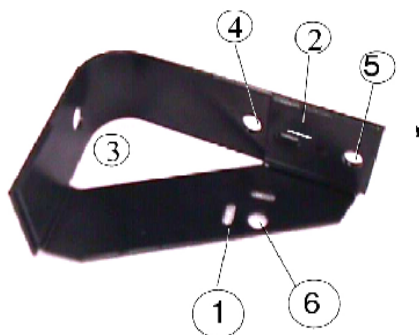

Fig. 2



SUPPORT BRACKET MOUNTS TO CROSS FRAME MEMBER UNDER FRONT OF TRUCK BED AT THE LOCATION SHOWN.



See reverse side for rear anchor installation.

# REAR ANCHOR INSTALLATION

**NOTE:** The diagram below shows driver's side installation. The same procedure and dimensions apply to the passenger side installation.

1. Looking at the end of the bumper, locate and mark a point mid way (center) from left to right, and 1-1/8" down from bottom of inset. (See Fig. 3 below)
2. Center punch, then drill 1/8" pilot hole at this point.
3. Enlarge hole to 1/2".
4. Install anchor bolt as shown in Fig. 3, with the flat surfaces horizontal. 
5. When loading camper, slide the angled tie down coupler (Fig. 4) over the anchor bolt and insert turnbuckles into the eye of the coupler.  
It is best to slip the turnbuckle hook through the coupler from the truck side outward.

NOTE: When camper is not loaded, remove and store Tiedown Couplers to avoid losing them.

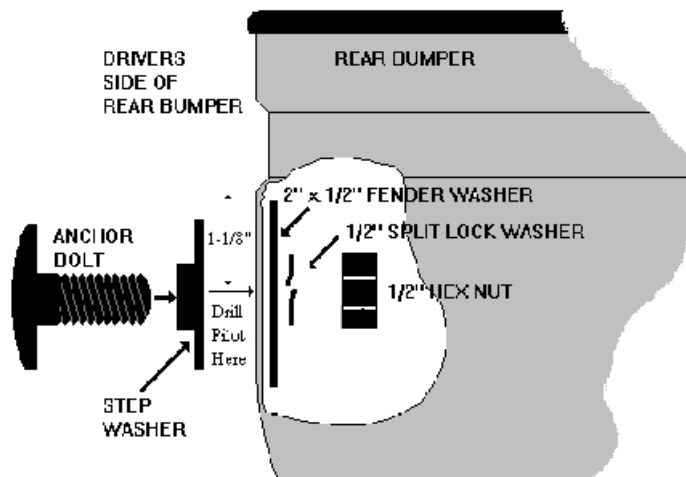

## WARRANTY INFORMATION

### TERMS OF THE WARRANTY:

All products manufactured by Happijac Co. are warranted to the retail customer for one year from date of purchase against defects in material or workmanship. Any defective part(s) will be repaired or replaced (at Happijac's option) without charge, when returned transportation prepaid. There are no other expressed warranties except as set forth above and any implied warranties are limited in duration to that of the expressed warranty. This warranty does not cover any damage due to misuse, negligence, or accidents. There is no warranty covering consequential damages, incidental damages, or incidental expenses including damage to property. This warranty gives you specific legal rights. You may have other rights which may vary from state to state.

### WARRANTY CLAIMS:

All defective material must be returned to the factory via prepaid shipment. Upon inspection and determination of claims warranted, the factory will repair/replace the material at no charge and return the repaired/replaced material to the customer with delivery charges prepaid by Happijac via common carrier of Happijac's choosing. Upgrades and changes to shipping mode resulting in additional shipping costs shall be at customers expense.



**HAPPIJAC®**

505 North Kays Drive, Kaysville UT 84037

Phone: (801) 544-2585

Fax: (801) 546-5241

Email: [happijac@happijac.com](mailto:happijac@happijac.com)

Web Address: [www.happijac.com](http://www.happijac.com)